

SPCM-AQRH

Single Photon Counting Module

Single Photon Counting APD - RoHS Compliant

- preliminary -



Introduction

The new RoHS compliant SPCM-AQRH is a self-contained module that detects single photons of light over the 400 nm to 1060 nm wavelength range - a range and sensitivity that often outperforms a photomultiplier tube.

The SPCM-AQRH uses a unique silicon avalanche photodiode with a circular active area that achieves a peak photon detection efficiency of more than 65% at 650 nm over a 180 μm diameter. The photodiode is both thermoelectrically cooled and temperature controlled, ensuring stabilized performance despite ambient temperature changes. Circuit improvements have reduced the overall power consumption.

Count speeds exceeding 20 million counts per second (Mc/s) are achieved by the SPCM-AQRH-1X module (> 30 million counts per second on some

models). There is a "dead time" of 35 ns between pulses but other values can be set at the factory.

As each photon is detected, a TTL pulse of 2.5 Volts (minimum) high in a 50 load and 15 ns wide is output at the rear BNC connector. To avoid a degradation of the module linearity and stability, a case temperature between 5°C and 40°C should be maintained.

This series of photon counting modules are designed and built to be fully compliant with the European Union Directive 2002/95/EEC – Restriction of the use of certain Hazardous Substances in Electrical and Electronic equipment (RoHS).

Features and Benefits

- EU RoHS compliant
- Peak photon detection efficiency at 650 nm: 65% typical
- Active area: 180 μm
- User friendly
- Gated output
- Single +5 V supply

Applications

- LIDAR
- Photon correlation spectroscopy
- Astronomical observation
- Optical range finding
- Adaptive optics
- Ultra sensitive fluorescence
- Particle sizing

Table of Contents

Features and Benefits	1
Applications	1
Saturation	3
Fiber Connection Option	3
Fiber Shielding	3
Gating Function	3
Light Emission During Photon Detection	3
Safety	3
RoHS Compliance	3
Warranty	4
EDS Warning	4
Individual Module Test Data	4
Operating Instructions	4
Table 1. Specifications of SPCM-AQRH-1X , @ 22 °C, all models, unless otherwise indicated.	5
Table 2. Absolute Maximum Ratings	6
Table 3. SPCM Ordering Guide	7
Table 4. Fiber Ordering Guide	7
“Your Partner of Choice”	10
PerkinElmer Optoelectronics	10

Saturation

The photon count decreases at higher incoming light levels. The count at which the output rate starts to decrease is called the saturation point. As an extreme example, if the module is exposed to intense light the count rate will fall to zero. While the module is protected against light overload, precautions should be taken to avoid any excessive light level that will damage the SPCM module.

Fiber Connection Option

The SPCM-AQRH-WX-FC has an “FC” fiber-optic receptacle pre-aligned to the optical detector. Optical fibers with an FC connector on one end are available separately, (see Ordering Guide 2). The standard fiber lens is optimized for 550nm. Though the fiber / GRIN in the standard module will function through the complete range of 400nm to 1060nm, due to the wavelength dependence of the graded index coupling lens, improvements to operating wavelengths other than 550nm are special orders. The photon detection efficiency of connectorized modules is about 95% of that quoted for standard modules at 550nm.

Fiber Shielding

When used with optical fibers, both the fiber itself and the connector shrouds must be completely opaque. Otherwise, stray light will increase the count rate. The SPCM-QCX pigtailed conform to this requirement (see Ordering Guide 2).

Gating Function

A gating function is provided with each module – useful for viewing a signal that occurs only in a small timeframe window. Also, in some applications the background light flux is higher than the signal. In this case, the gating option could be used to improve the S/N ratio by opening a window only when the light signal is present. The output of the module and the active quench function are disabled when a TTL low level is applied to the module gate input. When a TTL high level is applied to the module gate input, the output of the module and the active quench circuit are enabled again. Any photon detection that occurs less than 2µs before the module gate input changes can result in an output pulse. However, this output pulse has lost timing accuracy.

Light Emission During Photon Detection

One peculiarity of silicon avalanche photodiodes is that as an incoming photon is detected, a small amount of light is emitted from the avalanche region. The emitted light has a broad spectral distribution. In most cases, this is not a problem. However, it can cause some confusion if another detector is monitoring light, or if the optical system is such that light emitted from the SPCM-AQRH is reflected back on itself. If these photons return 35 ns after the initial event, they will be detected.

Safety



The SPCM-AQRH contains a **high voltage power supply**. Users may be injured if the case is opened. All internal settings are pre-set; there are no user adjustments.



Units that appear defective or have suffered mechanical damage should not be used because of possible electrical shorting of the high voltage power supply. Opening the case may damage sensitive components and expose the user to the risk of electrical shock. Please contact factory for repairs.

RoHS Compliance

This series of avalanche photodiode modules are designed and built to be fully compliant with the European Union Directive 2002/95/EEC – Restriction of the use of certain Hazardous Substances in Electrical and Electronic equipment.



Warranty

A standard 12-month warranty following shipment applies. Any warranty is null and void if the module case has been opened. Warranty is null and void if the module input exceeds 5.5V or the polarity of the +5V supply is reversed.

EDS Warning

Modules should only be handled at an ESD-safe work station.

Individual Module Test Data

Each module is supplied with test data indicating the module's actual dark count, dead time, pulse width, photon detection efficiency @ 630nm (550nm for fiber coupled versions), correction factor and linearity.

Operating Instructions

1. Connection to incorrect voltage or reverse voltage may damage or destroy the module. The warranty is invalid where such damage occurs. The center contact of the barrel type power connector (corresponds to the white stripe on the wire) is +5V.
2. These modules are not qualified for shock or vibration other than normal instrumentation environments.
3. The module dissipates a mean power of 2.5W and a maximum power of 6W at high count rate and 40°C. Adequate heat sinking must be provided by clamping the module to a suitable heat sink via the holes in the module base. For the specification performance, the module case temperature must not exceed 40°C. The maximum case operating temperature can reach 50°C at reduced count rate.
4. Bi-stability of the dark count: On a small percentage of delivered modules, bi-stability of the dark count has been observed. Research indicates this bi-stability is probably due to transitions at a single impurity site between a low energy and a high energy state.

The phenomenon is seen as an abrupt change in the dark count rate, e.g., 350 to 390 c/s., and the dark count switches between the two states at a rate dependent upon the detector temperature. Multilevel switching has also been observed, where more than one impurity site is switching.

5. Long-term bi-stability is related to fundamental semiconductor physics and is beyond PerkinElmer's control. Warranty claims will not be considered against bi-stability alone.

Warranty claims will only be considered if the high level of the dark count exceeds the maximum level in the specification.

6. In the dark, the module generates random counts that follow a Poisson distribution. In a Poissonian process, the standard deviation is equal to the square root of the average count. In this specification the "dark count variation" refers to the stability of the average count of the module.
7. The actual photon rate could be calculated using the following equation, as indicated below:
8. Typical count rate can go up to 35 Mc/s on some units.
9. Output pulse width is set at the standard of 15ns. Optional output pulse width is 28ns. If the application requires a 28ns output pulse width, it should be requested at the time of order.

ACTUALCOUNTRATE $_{Photons} = \frac{(OUTPUT \text{ ModuleCountRate} \times CORRECTIONFACTOR @ \text{ the Module CountRate}) - DARK \text{ COUNT Module}}{PHOTON \text{ DETECTION EFFICIENCY Module}}$

The theoretical value, at low count rate, of the Correction Factor follows this equation:

$$Correction \text{ Factor} = \frac{1}{1 - (t_d \times C_R)}$$

Where: $t_d = \text{Module Dead Time}$
 $C_R = \text{Output Count Rate}$

The deviation from an ideal linear system is another way of looking at the saturation effect. The following equations show how to calculate this departure from the linearity:

$$LINEARITY = \left[\frac{OUTPUT \text{ ModuleCountRate}}{(PHOTONS \text{ Actual Count Rate} \times PHOTON \text{ DETECTION EFFICIENCY Module}) + DARK \text{ COUNT Module}} \right]^{-1}$$

$$= \left[\frac{1}{Correction \text{ Factor}} \right]^{-1}$$

Table 1. Specifications of SPCM-AQRH-1X , @ 22 °C, all models, unless otherwise indicated.

Parameter	Min	Typ	Max	Unit
Supply current		0.3	1.2	A
Supply voltage ⁽¹⁾	4.75	5.0	5.25	V
Power cable total resistance		0.1	0.2	Ω
Case operating temperature ^(1, 3)	5		40	°C
Active area (diameter) at minimum Pd	170	180		μm
Photon detection efficiency (Pd) at:				%
400nm	2	5		%
650nm	50	65		%
830nm	35	45		%
1060nm	1	2		%
Pd variation at constant case temperature (2hrs at 25 °C)		± 1	± 3	%
Pd variation from 5 °C to 40 °C		± 4	± 10	%
Dark Count ^(4, 5, 6)				Counts /second
SPCM-AQRH-10			1500	
SPCM-AQRH-11			1000	
SPCM-AQRH-12			500	
SPCM-AQRH-13			250	
SPCM-AQRH-14			100	
SPCM-AQRH-15			50	
SPCM-AQRH-16			25	
Average dark count variation at constant case temperature (6 hrs at 25 °C) ^(4, 5, 6)				%
SPCM-AQRH-10, 11, 12, 13			± 10	%
SPCM-AQRH-14, 15, 16			± 1	σ

Parameter	Min	Typ	Max	Unit
Average dark count variation at 5 °C to 40 °C case temperature for ^(4, 5, 6) SPCM-AQRH-10, 11, 12, 13 SPCM-AQRH-14, 15, 16			± 20 ± 2	% σ
Single photon timing resolution		Contact factory for availability		ps
Dead time (count rate below 5M/c)		32	40	ns
Output count rate before saturation ⁽⁸⁾	20	29		Mc/s
Linearity correction factor ⁽⁷⁾ at				
200 Kc/s		1		
1 Mc/s		1.03		
5 Mc/s		1.2		
10 Mc/s		1.48		
20 Mc/s		2.8		
25 Mc/s		4.5		
Afterpulsing probability		0.5		%
Setting time following power up (1% stability) at 1 Mc/s and 25 °C		15	20	s
Threshold setting required on counter for digital output pulse (terminate in 50Ω)		1.0		V
Output pulse width ⁽⁹⁾		15		ns
Gating turn on/off (50Ω output)				
Disable = TTL low (<0.8V)		26	32	ns
Enable = TTL high (>2.0V)		52	61	
Gating threshold voltage (at V supply = 5V)				
Low level (sink current >90mA)	0		0.4	V
High level (sink current >30mA)	2.0		5.25	

Refer to Operating Instructions for noted items

Table 2. Absolute Maximum Ratings

Supply voltage ⁽¹⁾	5.5 V
Maximum count rate	Maximum count rate can be sustained if case temperature is maintained within limit specified limits.
Peak light intensity	10 ⁴ photons per pulse and pulse width < 1ns
Case temperature ⁽³⁾	-20 °C/+70 °C storage, +5 °C /+40 °C operating (+50°C at reduced count rates).

Table 3. SPCM Ordering Guide

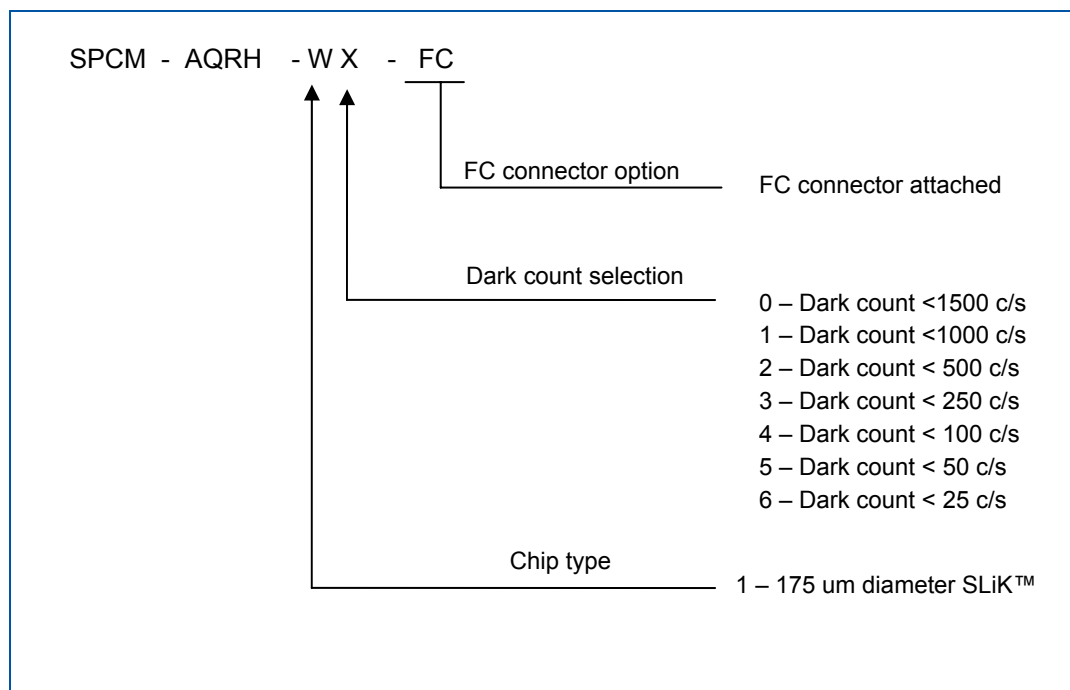

Table 4. Fiber Ordering Guide

Part Number	Fiber Type	Connector Type	Diameter			Numerical Aperature
			Core	Cladding	Outer	
SPCM-QC4	Multimode	FC / Bare	62.5 μm	125 μm	2.5 mm	0.27
SPCM-QC6	Multimode	FC / Bare	100 μm	140 μm	2.5 mm	0.29
SPCM-QC8	As SPCM-QC6 but 905 SMA on free end, 100 microns core fiber					
SPCM-QC9	As SPCM-QC6 but FC connector on free end, 100 microns core fiber					

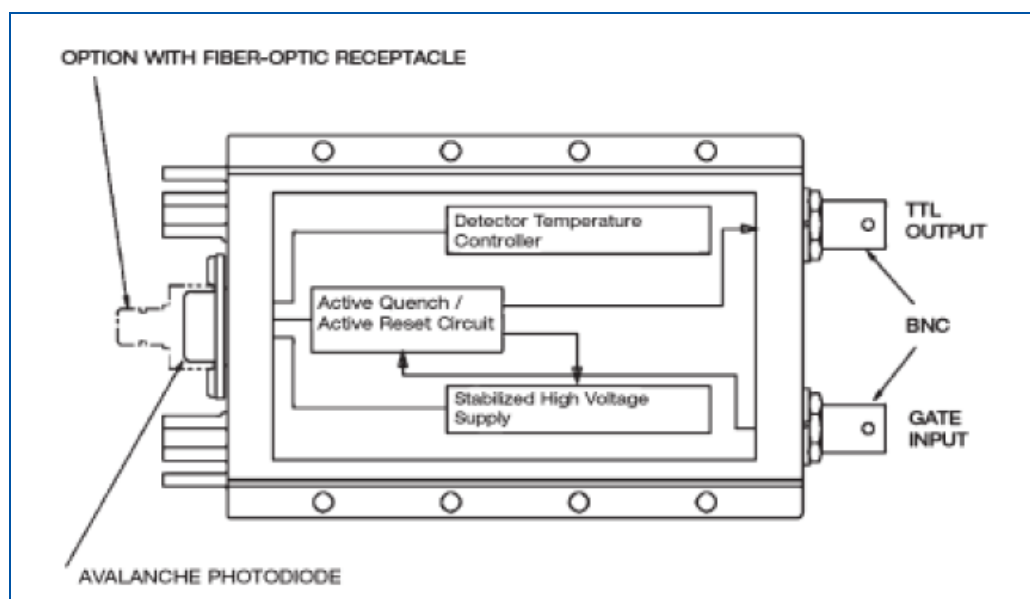

Figure 1
Module Block Diagram

OUTPUT CONNECTOR

The digital OUTPUT pulse (BNC connector, TTL levels, >2.0v) should be terminated into a 50 ohm load to avoid distortion and ringing. A 1.0 volt triggering level is recommended on counters and oscilloscopes to avoid triggering on noise. Note that TTL stands for Transistor Transistor Logic.

GATE CONNECTOR

The GATE input (BNC connector) impedance is 50 ohms and internally connected to the +5 volt supply through a pull-up resistor (standard module versions). It can be driven by standard TTL level signals.

POWER CONNECTOR

The +5volt power connector is a standard barrel connector (2.5mm I.D., 5.5mm O.D.) with an 18 AWG cable. The center stripe corresponds to the center of the barrel and connects to the positive terminal of the 5 volt supply. Reversal of the wires may damage the module.

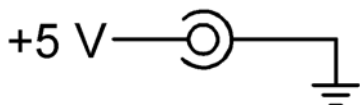

Figure 2
Electrical Connections

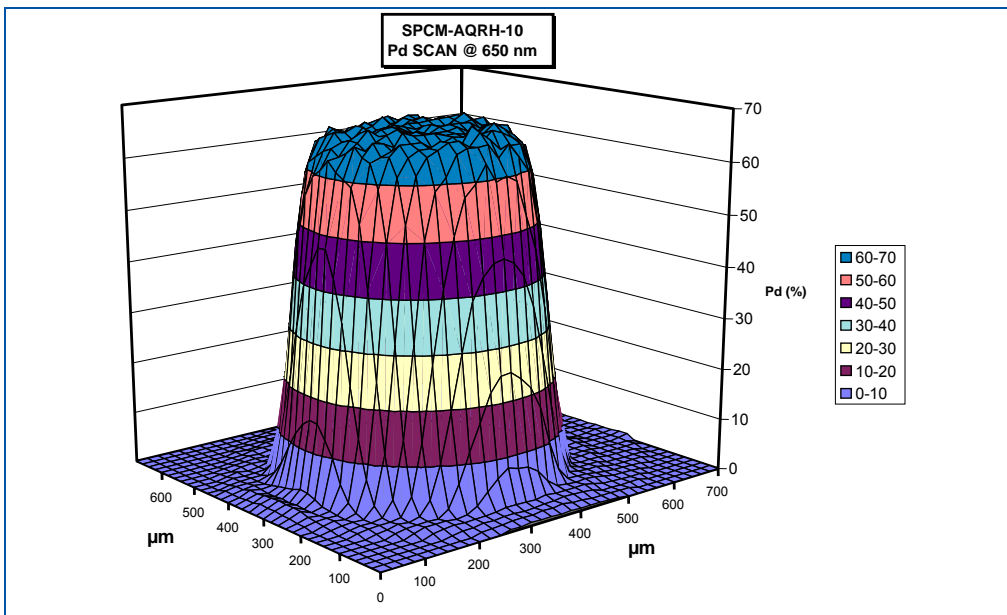

Figure 3
Typical Pd Scan

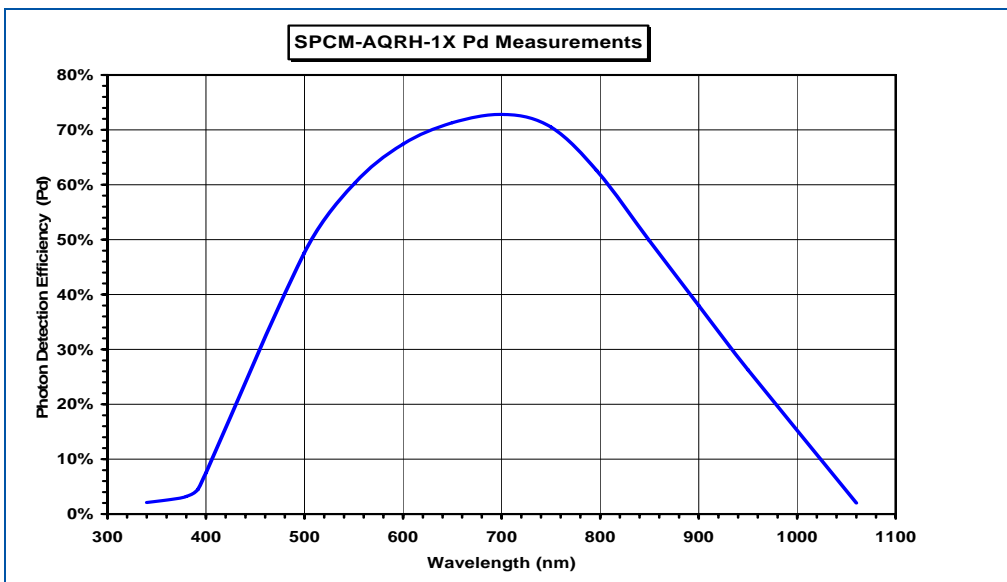

Figure 4
Typical Photon
Detection Efficiency
(Pd) vs. Wavelength

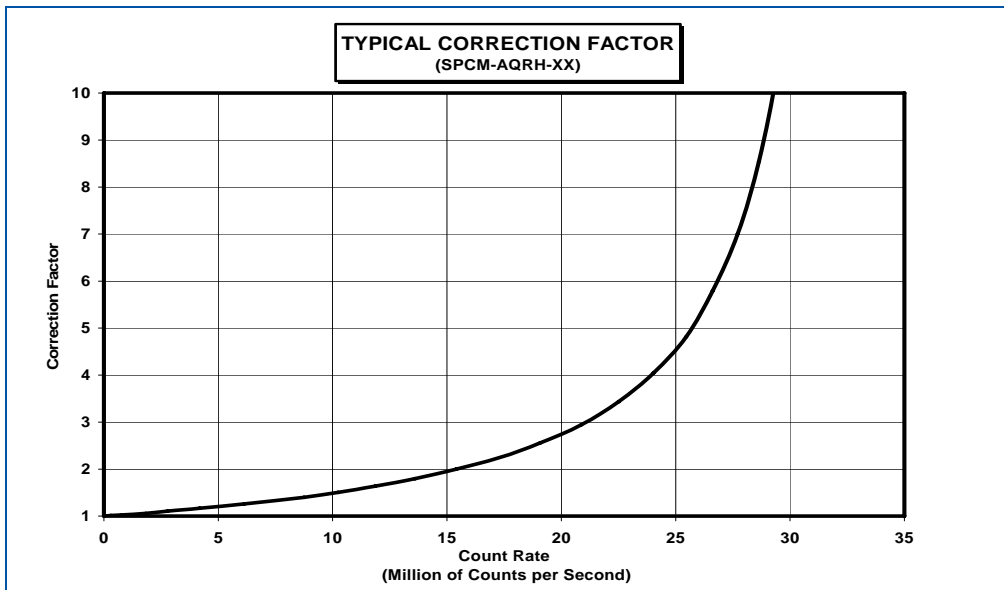

Figure 5
Typical Correction
Factor

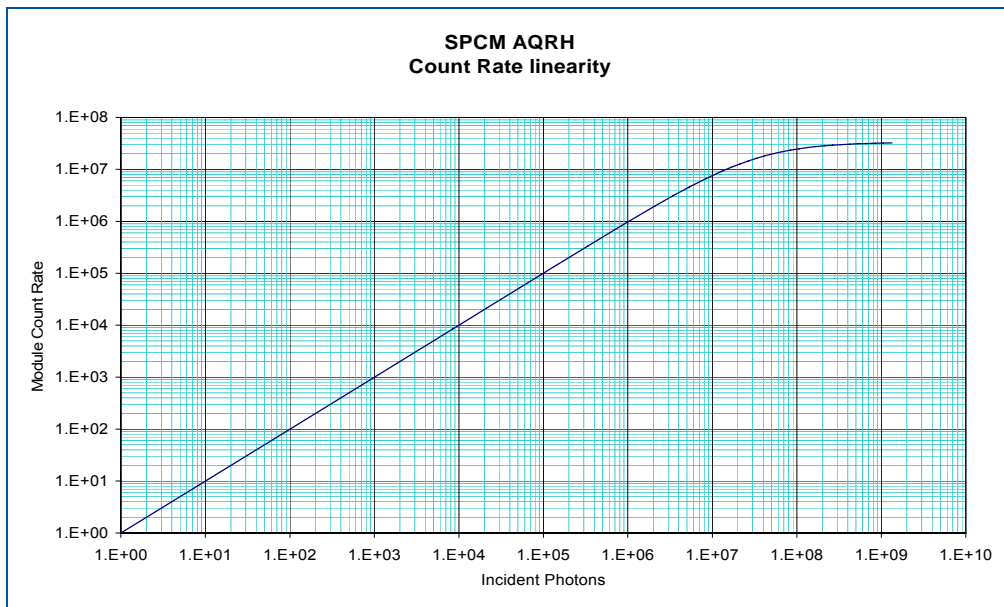

Figure 6
Count Rate Linearity

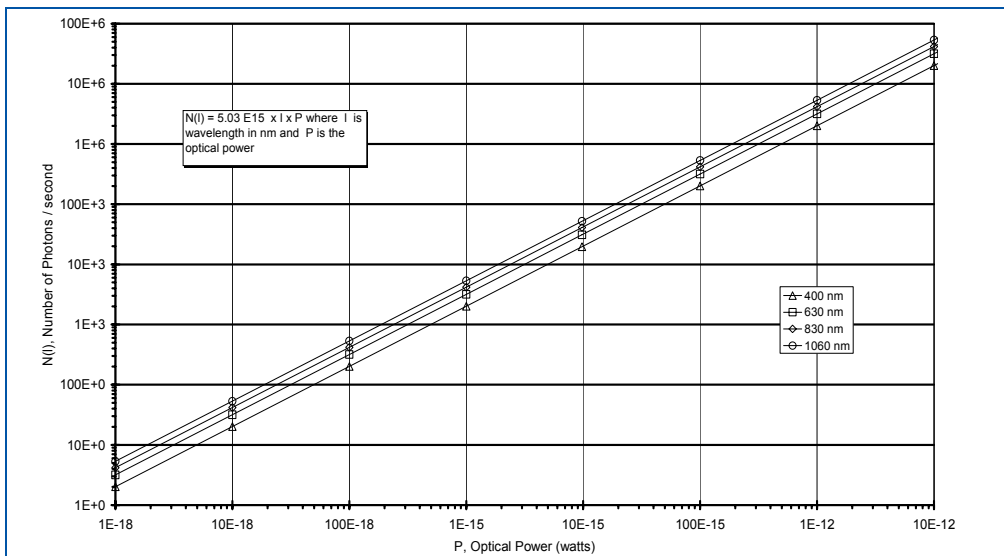

Figure 7
Optical Power vs. Number
of Photons

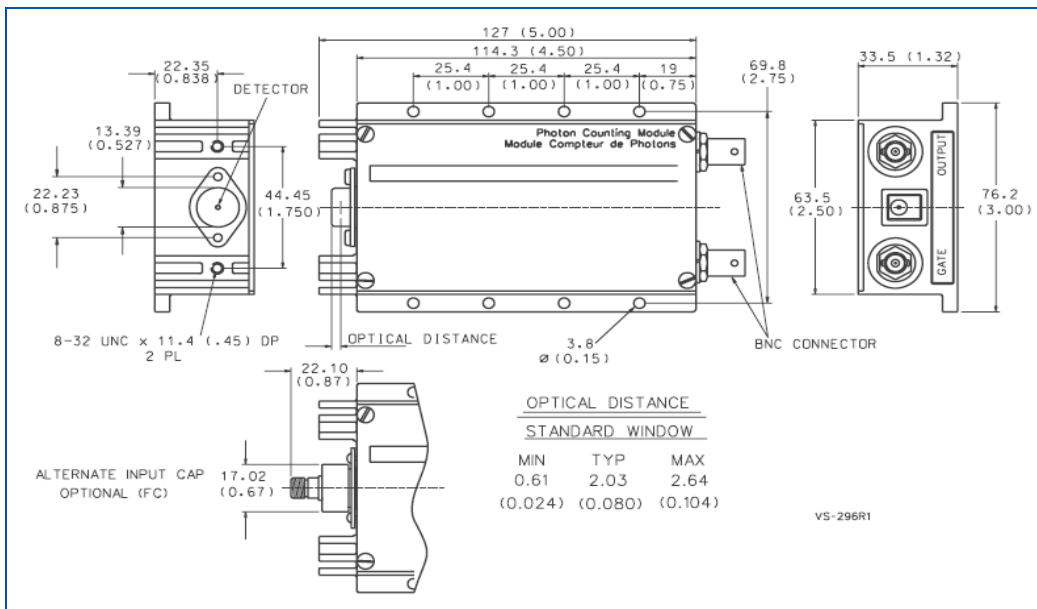

Figure 8
Dimensional
Outline

“Your Partner of Choice”

With a broad customer base in all major markets, built on ninety years of solid trust and cooperation with our customers, PerkinElmer is recognized as a reliable partner that delivers high quantity, customized, and superior "one-stop" solutions. Our products – from single photocells to complex x-ray inspection systems - meet the highest quality and environmental standards.

Our worldwide Centers of Excellence, along with our Customer and Technical Support teams, always work with you to find the best solutions for your specific needs.

PerkinElmer Optoelectronics

PerkinElmer Optoelectronics is a global technology leader providing market-driven, integrated solutions for a wide range of applications, which leverage our lighting, sensors, and imaging expertise. Our technologies, services and support are fuelling the medical, genomic and digital revolutions by enhancing our customers' productivity, optimizing performance, and accelerating time to market.

So contact us and put PerkinElmer's expertise to work in your demanding applications. We will show how our innovations will help you deliver the perfect product.

Worldwide Headquarters
PerkinElmer Optoelectronics
 44370 Christy Street
 Fremont, CA 94538-3180
 Telephone: +1 510-979-6500
 Toll free: (North America) +1 800-775-OPTO (6786)
 Fax: +1 510-687-1140
 Email: opto@perkinelmer.com
www.optoelectronics.perkinelmer.com

European Headquarters
PerkinElmer Optoelectronics
 Wenzel-Jaksch-Str. 31
 65199 Wiesbaden, Germany
 Telephone: (+49) 611-492-247
 Fax: (+49) 611-492-170
 Email: opto.Europe@perkinelmer.com

Asia Headquarters
PerkinElmer Optoelectronics
 47 Ayer Rajah Crescent #06-12
 Singapore 139947
 Telephone: (+65) 6775-2022
 Fax: (+65) 6775-1008
 Email: opto.Asia@perkinelmer.com



For a complete listing of our global offices, visit www.optoelectronics.perkinelmer.com
 ©2007 PerkinElmer, Inc. All rights reserved. The PerkinElmer logo and design are registered trademarks of PerkinElmer, Inc. All other trademarks not owned by PerkinElmer, Inc. or its subsidiaries that are depicted herein are the property of their respective owners. PerkinElmer reserves the right to change this document at any time without notice and disclaims liability for editorial, pictorial or typographical errors.
 600092_03 DTS0807