

Versatile Radiation Controller for Industry and Science



Versatile Radiation Controller for Industry and Science

The RADIKON is used to control the value generated by a detector (e.g. radiation sensor or a pressure sensor). If the detector value falls below a certain setpoint value a relay is activated where a valve, an alarm buzzer or other modules can be connected.

The **highlight of the RADIKON** is its high versatility making the module very interesting to industrial developers who need to match the controller with different input signals. The RADIKON can read the generic current of a photodiode ($5\text{nA} < I_{\text{Sensor}} < 5\mu\text{A}$) as well as $0 \dots x$ Volt and $0(4) \dots 20\text{mA}$ probe signals. The value x is user definable.

The RADIKON outputs a voltage of $0 \dots 10\text{V}$ which can be used to attach a separate display or to connect the RADIKON with a PID controller. A multicolour LED changes its colour with the radiation intensity level. In addition to these features, the easy set up and configuration make the RADIKON a perfect tool for developers or manufacturers of small series. For medium series controller modules with customised properties are offered.

Specifications

Input values Type:

Generic sensor signal, e.g. photodiode current

Voltage input

Current input
(current loop)

Adjustable setpoints

Other properties:

Inputs

Power supply

Values:

$0 \dots x$ nA
 x can be configured (with jumpers) to 50nA, 150nA, 500nA, 1,5 μA and 5 μA , other values are possible by soldering a feedback resistor

$0 \dots x$ Volt
 x can be configured (with jumpers) to 50mV, 142mV, 450mV, 1160mV, 2500mV and 10V other values are possible by soldering a feedback resistor

$y \dots 20$ mA
 y can be configured (with jumpers) to 0mA or 4mA

relay setpoint
 multi colour LED

DC-isolated, EMC and EDS conform

12...24VDC

Output values Type:

Relay

Voltage Output

Multi colour LED

Other LEDs

Dimensions and weight

Conformities

Properties:

free floating, 250VAC, 2A

$0 \dots 10\text{V}$

„green“ = Value OK
 „blue“ = Value critical
 „red“ = Value too low

status of the relay,
 warmupdelay,
 activity

$B \times H \times T = 22,5 \times 99 \times 114,5$ mm
 (top hat rail EN 50022) ,
 $m = 72\text{g}$
 ROHS, CE

How to set up the RADIKON

Using the potentiometers „SET POINT HIGH“ and „SET POINT LOW“ the setpoints for the value “good” = LED is green to value “critical” = LED is blue (SET POINT HIGH) and for the value “critical” to “too low” = LED is red (SET POINT LOW) can be adjusted.

Please start with adjusting SET POINT LOW by creating an input value which equals to a signal which is quite between “critical” and “too low”. Turning right of the potentiometer shifts the setpoint towards lower signal level and turning left shifts it towards higher signal level. After turning the potentiometer the module needs 5 seconds to store the value. Now your RADIKON is ready to use.

Additionally you may also adjust a setpoint for the value “good” to “critical”. This feature is particularly interesting if the decline of the signal intensity (e.g. the aging of a lamp) needs be monitored before the signal is too low. To set the value the source, e.g. the lamp, needs to be adjusted at that point. Now, analogue to the above procedure the setpoint can be configured while turning the SET POINT HIGH potentiometer. The colour of the LED changes from green=good to blue=critical.

How to use the RADIKON

After powering on the RADIKON a 100ms self test starts. Then the LED “POWER” is on and a 180s warm up delay starts. During the warm up delay the LED “STATE” is on and the LED “RADIATION” is green. That means that during the first 180s each input value is interpreted as “good”.

This feature is important to avoid false alarms during warm up of the lamps to measure. If you need another warm up delay please inform us with your order. After the warm up delay the RADIKON is ready. If the input value is OK the LED is green, is it critical the LED is blue and is it too low the LED is red and the relay changes its position. If zero input is present (e.g. sensor failure) the LED blinks red. In case of overrange the LED blinks green.

The Outputs of the RADIKON

The response the RADIKON calculates based on the input value can be read using two different methods:

Relay Output

The free floating relay output is connected with the terminals “NO” and “COM” if the relay should be “normally open”. If “normally closed” is needed please connect with “NC” and “COM”.



0-10V – Output

This output is to be connected with the terminals “AO” and “-“. You can use this output to connect a display or to use the 0-10V output as actual value input of a PID regulator.

The Inputs of the RADIKON

The RADIKON is able to read all common sensor outputs. Below the wiring for the different sensor outputs is explained:

Wiring of a Photodiode or another small current source

- Anode (+) to terminal PD+
- Cathode (-) to terminal PD-
- Shielding to terminal –
- Please consider that cable length must be as short as possible

Configuration of the Photodiode input

If you like to use the generic photodiode input at first you need to know about the typical current coming from your photodiode. The RADIKON works with currents from 50nA and 5µA. By default the unit is set to a typical current of 150nA. If your sensors gives another current please open the RADIKON's housing and remove the PCB. The picture at the right side shows the different jumper positions. If your current is below 50nA or above 5µA please set the jumper to „VAR“ and solder a special 0804 SMD resistor calculated by the formula $R_{VAR} = 5000/I$, where R_{VAR} is given in MΩ, and I, the photodiode current you need is given in nA. The value C_{VAR} calculates by $C_{VAR} = 0,1s / R_{VAR}$

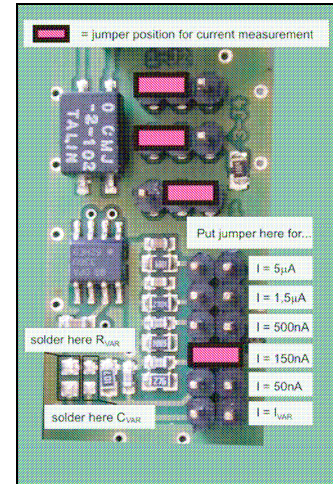

Jumper positions for photodiode input

Wiring Sensor Voltage 0-10V:

- Anode (+) to terminal AI
- Cathode (-) to terminal –
- Bridge from F2 to +

Configuration of the Voltage input 0-10V:

No configuration is needed. No jumpers must be moved.

Wiring Sensor Voltage 0-x V

- Anode (+) to terminal PD+
- Cathode (-) to terminal PD

Configuration of the Voltage input 0-xV:

The maximum Value x is the maximum voltage your sensor outputs. If this max. voltage is not 10V you need to configure another max. voltage with the jumpers as shown at the right side picture. You can select max. values $x = 50mV, 142mV, 450mV, 1160mV$ or $2500mV$. If your max. voltage is below 50mV or above 2,5V please set the jumper to „VAR“ and solder a special 0804 SMD resistor calculated by the formula $R_{VAR} = 5000/U$, where R_{VAR} is given in MΩ, and U, the photodiode current you need is given in mV. The value C_{VAR} calculates by $C_{VAR} = 0,1s / R_{VAR}$

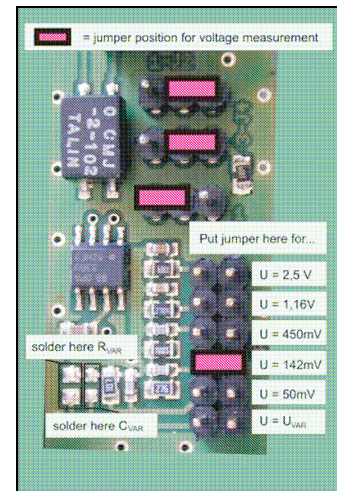

Jumper positions for sensor voltage 0-x Vinput

Wiring Sensor Current 0-20mA:

- Anode (+) to terminal +
- Cathode (-) to terminal AI
- 500 Ω - Resistor from AI to – (included in the delivery)
- Bridge from + to F2

Configuration of the Sensor Current input 0-20mA:

No configuration is needed. No jumpers must be moved.

Wiring Sensor Current 4-20mA:

- Anode to terminal +
- Cathode to terminal AI
- 500 Ω - Resistor from AI to –
- Bridge from + to F1

Configuration of the Sensor Current input 4-20mA:

No configuration is needed. No jumpers must be moved.

Wiring Power Supply 12-24VDC:

- Terminals + and -